

**JAL-OV7725-DVR-001 V2.0****OmniVision OV7725 DVP paralelo Interfaz Foco fijo 0.3MP VGA Módulo de cámara**

<b>Módulo de cámara No.</b>	<b>JAL-OV7725-DVR-001 V2.0</b>
<b>Sensor de imagen</b>	OV7725
<b>EFL</b>	3.27 mm
<b>F.NO</b>	3.0
<b>Pixel</b>	480 x 640
<b>Ángulo de visión</b>	68°
<b>Tipo de lente</b>	1/4 pulgada
<b>Dimensiones de la lente</b>	10.00 x 10.00 x 11.00 mm
<b>Tamaño del módulo</b>	100.00 x 36.00 mm
<b>Tipo de módulo</b>	Foco fijo
<b>Interfaz</b>	DVP paralelo

**N. ° de pieza del conector de acoplamiento. FH12A-24S-0.5SH**

Conector de acoplamiento en la placa principal. Se vende por separado.

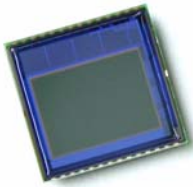

# OV7725 VGA product brief

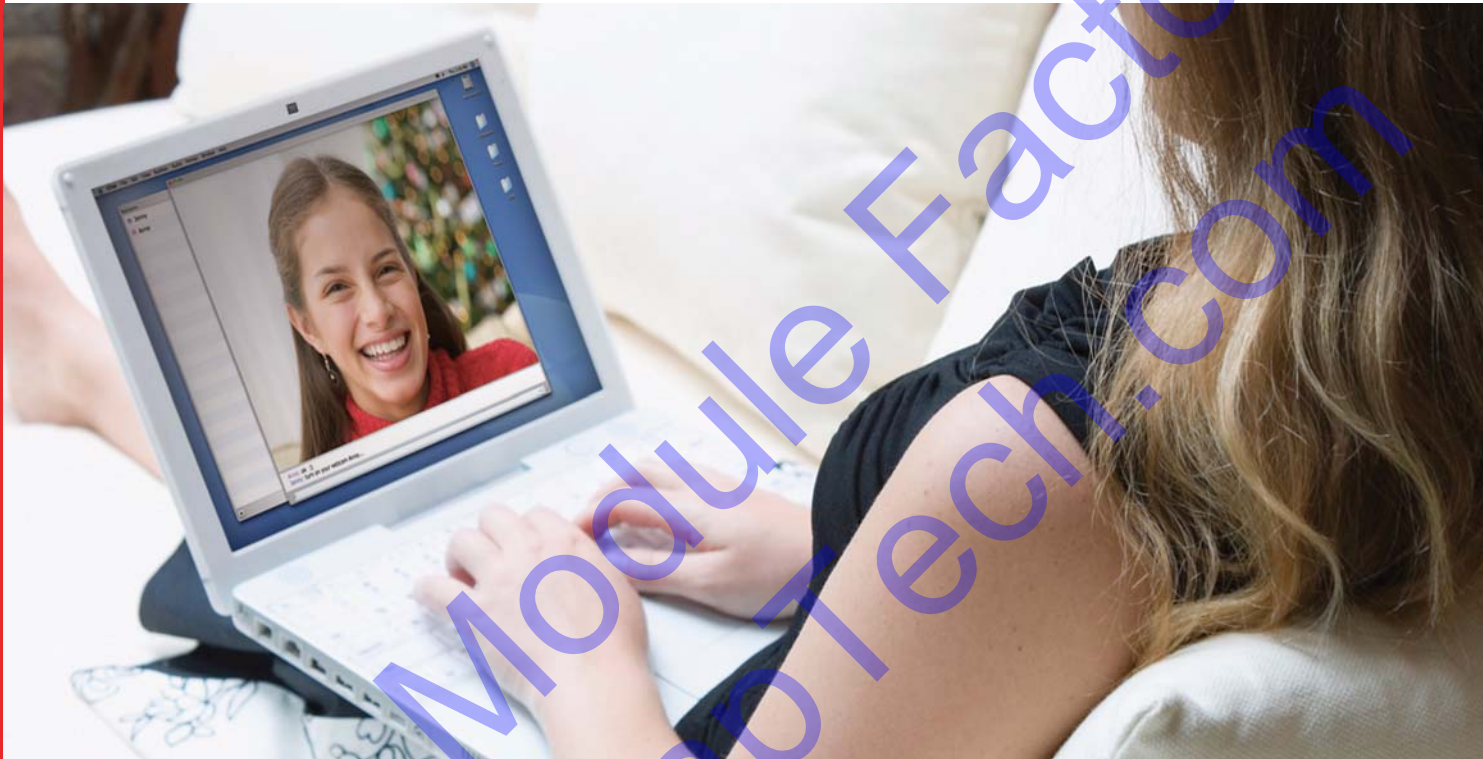

available in  
a lead-free  
package

## High Performance, All-digital VGA Camera Solution

The OV7725 CameraChip™ sensor is a high-performance 1/4 inch, single-chip VGA camera and image processor in a small footprint package. Operating at full functionality, the OV7725 meets all PC multimedia and cameraphone market requirements in terms of performance, quality and reliability. The low-power OV7725 excels in low light conditions and can operate in a wide temperature range, from -20°C to +70°C.

The OV7725 incorporates a 640 x 480 image array, capable of operating at 60 frames per second in VGA mode with complete user control over image quality, formatting and output data transfer.

The OV7725 provides full-frame, sub-sampled or windowed 8-bit/10-bit images in a wide range of formats, controlled through the serial camera control bus (SCCB) interface. The OV7725 possesses all required camera processing functions including exposure control, gamma, white balance, color saturation, hue control and more. These functions are also programmable through the SCCB interface.

Find out more at [www.ovt.com](http://www.ovt.com).

## Applications

- camera phones
- toys
- digital still cameras
- webcams

# OV7725

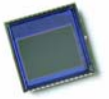

## ordering information

- OV07725-V28A  
(color, lead-free, CSP2-28)
- OV07221-V28A  
(b&w, lead-free, CSP2-28)

## Product Features

- high sensitivity for low-light operation
- standard SCCB interface
- output support for:
  - raw RGB
  - RGB (GRB 4:2:2, RGB565/555/444)
  - YCbCr (4:2:2) formats
- supports image sizes: VGA, QVGA, and any size scaling down from CIF to 40x30
- VarioPixel® method for sub sampling
- automatic image control functions including:
  - automatic exposure control (AEC)
  - automatic gain control (AGC)
  - automatic white balance (AWB)
  - automatic band filter (ABF)
  - automatic black-level calibration (ABLC)
- image quality controls including color saturation, hue, gamma, sharpness (edge enhancement), and anti blooming
- ISP includes noise reduction and defect correction
- lens shading correction
- saturation level auto adjust (UV adjust)
- edge enhancement level auto adjust
- noise suppression technology auto adjust
- frame synchronization capability

## Product Specifications

- array size: 640 x 480
- power supply
  - analog: 3.0V to 3.6V
  - digital core: 1.8 VDC  $\pm$  10%
  - I/O: 1.7V to 3.3V
- power requirements
  - active: 120 mW (60 fps VGA, YUV)
  - standby: <20  $\mu$ A
- temperature range: -20°C to +70°C
- output formats:
  - 8-bit YUV/YCbCr 4:2:2, RGB565, 555/444, GRB 4:2:2, Raw RGB Data, 10-bit Raw RGB Data
- lens size: 1/4"
- lens chief ray angle: 25° non-linear
- maximum image transfer rate:
  - 60 fps for VGA
- scan mode: progressive
- electronic exposure
  - up to 510:1 (for selected fps)
- sensitivity: 3800 mV/lux-sec
- max S/N ratio: 50 dB
- dynamic range: 60 dB
- pixel size: 6.0  $\mu$ m x 6.0  $\mu$ m
- fixed pattern noise:
  - < 0.03% of V<sub>PEAK-TO-PEAK</sub>
- dark current: 40 mV/s
- image area:
  - 3984  $\mu$ m x 2952  $\mu$ m
- package dimensions:
  - CSP2: 5345  $\mu$ m x 5265  $\mu$ m
  - COB: 5360  $\mu$ m x 5260  $\mu$ m

## Functional Block Diagram

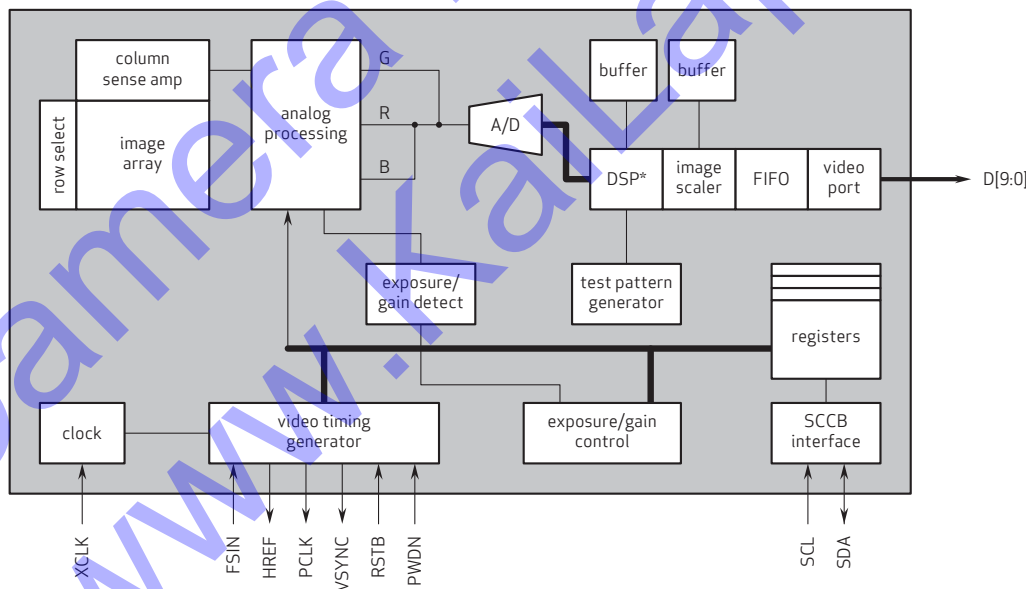

note 1 DSP\* (lens shading correction, de-noise, white/black pixel correction, auto white balance, etc.)

7725\_PB\_001

4275 Burton Drive  
Santa Clara, CA 95054

tel: +1 408 567 3000  
fax: +1 408 567 3001  
www.ovt.com

OmniVision reserves the right to make changes to their products or to discontinue any product or service without further notice. 'OmniVision', the OmniVision logo, 'VarioPixel', and 'OmniPixel' are registered trademarks of OmniVision Technology. All other trademarks are the property of their respective owners.

**OmniVision**